

Nyquist-Rate A/D Converters – A General Overview

Dr. Clemens Hammerschmied

October 22nd, 2001

Outline

- ❑ Applications of Nyquist ADCs

- ❑ Specifications of Nyquist ADCs
 - static
 - dynamic

- ❑ Basic High-Speed ADC

- ❑ Architectural Improvements
 - from Flash to Pipelined Converter
 - from Flash to Folding and Interpolation Converter

Applications of Nyquist A/D-Converters

hard disks

6 Bit > 500 MS/s

flat panel displays

8 Bit > 100 MS/s

imaging

10 Bit > 30 MS/s

communications

- base stations

10-12 Bit > 50 MS/s

- wireline modems

12-14 Bit > 5 MS/s

Static Specifications of Nyquist A/D-Converters (I)

ideal quantizer

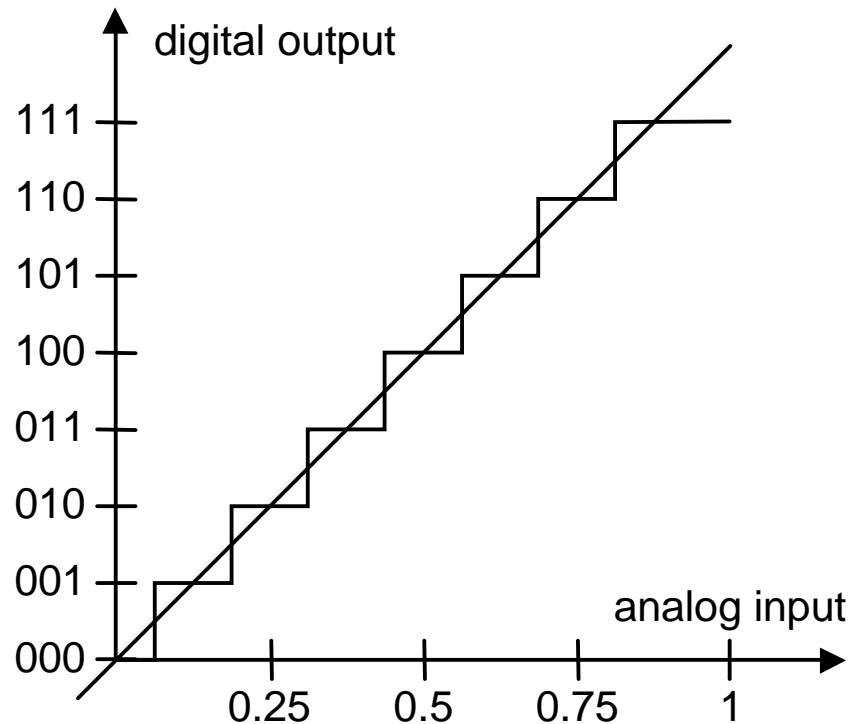

static errors

- offset error
- gain error
- integral nonlinearity (INL)
- differential nonlinearity (DNL)

Static Specifications of Nyquist A/D-Converters (II)

offset error

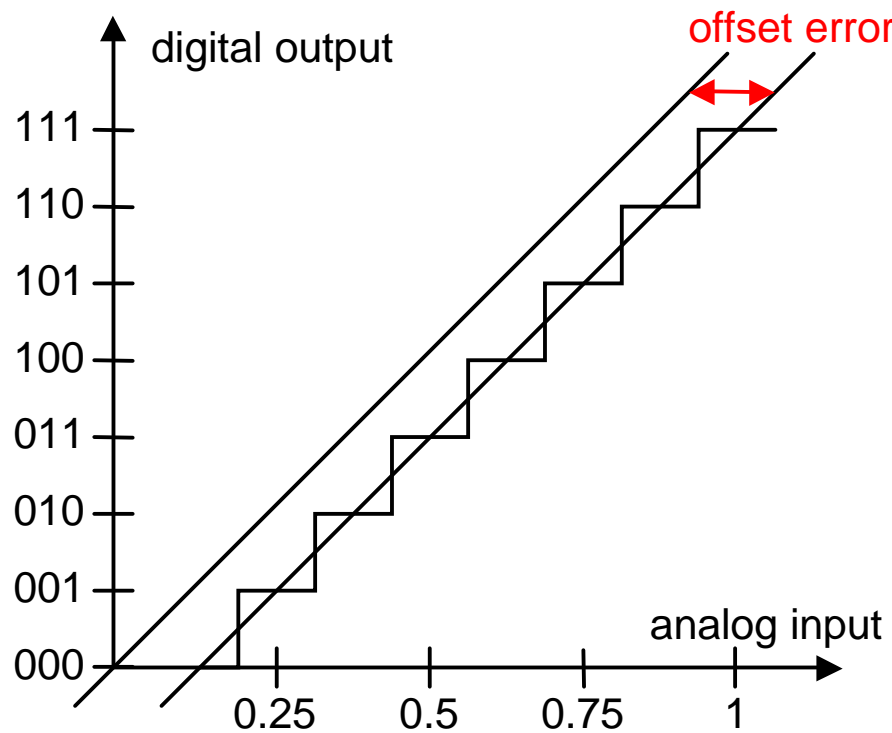

gain error

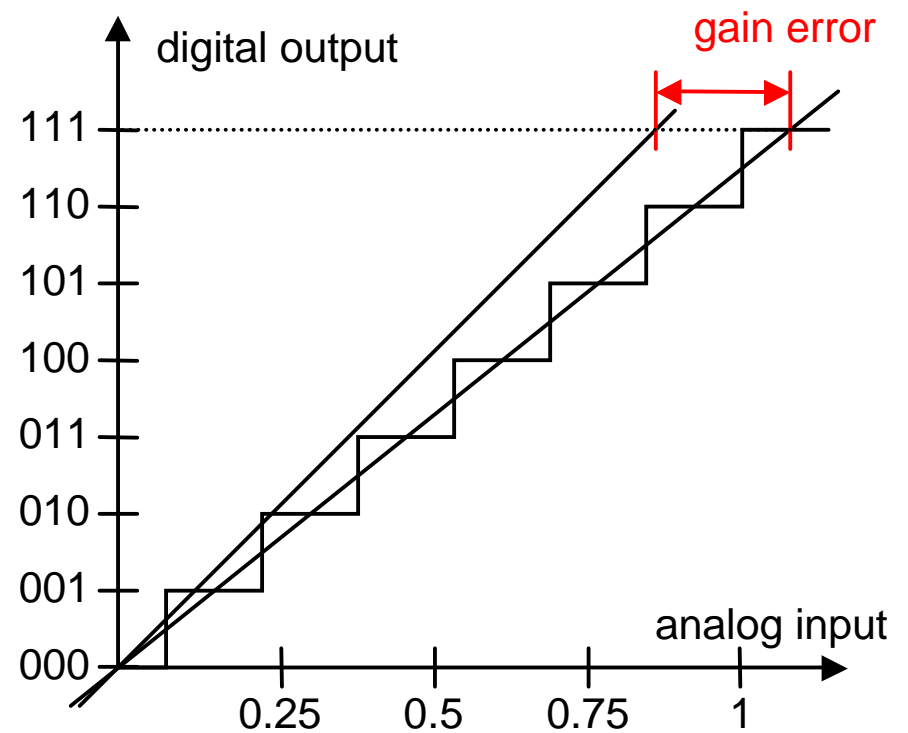

Static Specifications of Nyquist A/D-Converters (III)

nonlinearity

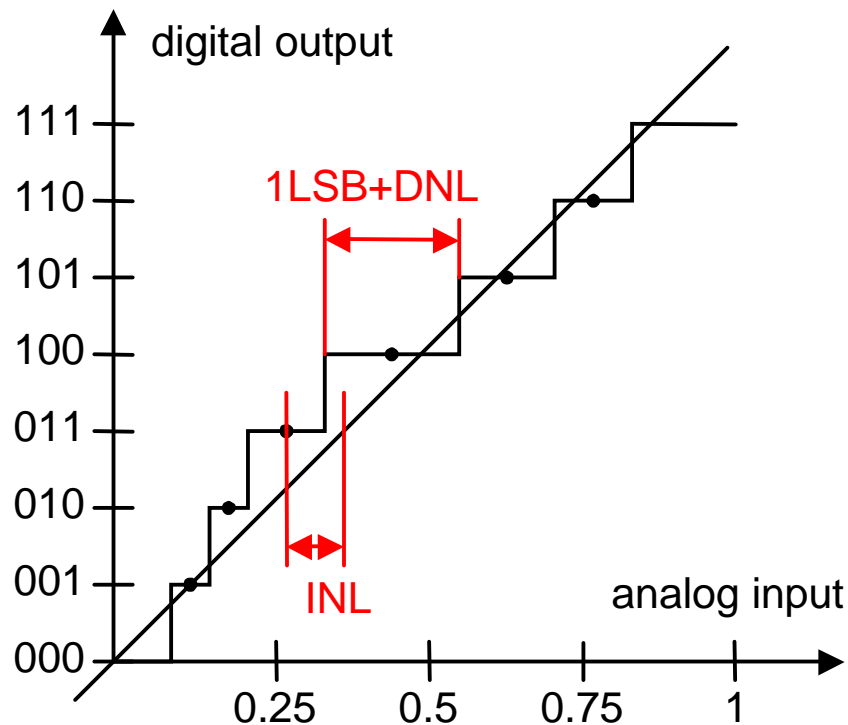

- DNL:
deviation of real code width
from ideal code width
- INL:
deviation of code center
from best fit straight line
(determined by code transitions)

Static Specifications of Nyquist A/D-Converters (IV)

ideal quantizer

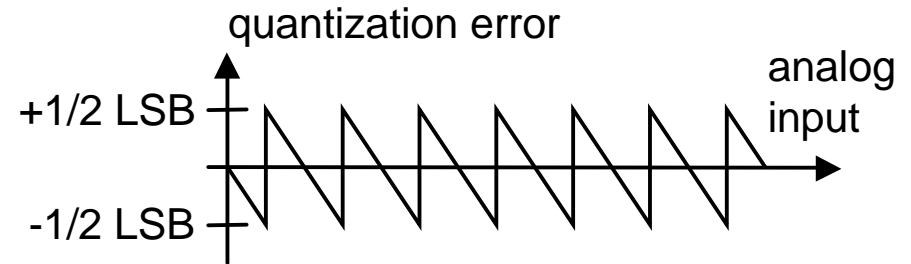
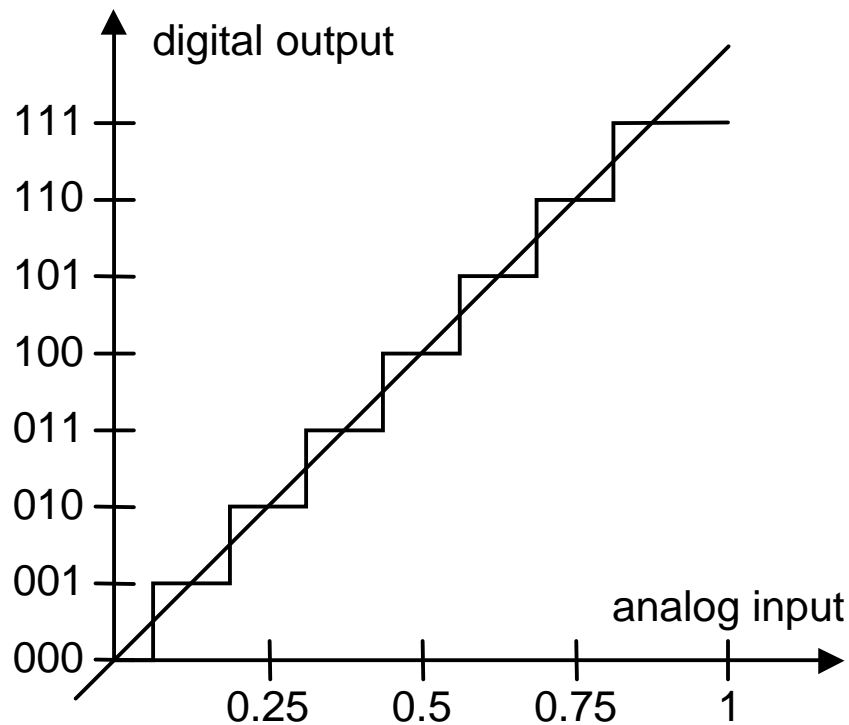

- quantization error random
⇒ quantization noise
- uniform distribution

$$\sigma^2 = \int_{-\frac{\text{LSB}}{2}}^{+\frac{\text{LSB}}{2}} \frac{1}{\text{LSB}} \cdot q^2 \cdot dq = \frac{\text{LSB}^2}{12}$$

$$\sigma = \frac{\text{LSB}}{\sqrt{12}}$$

Quantization Noise

ideal quantizer

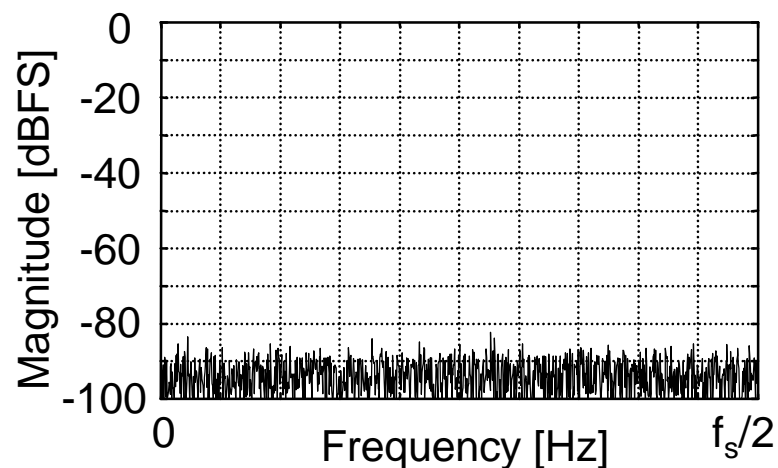

- ❑ quantization noise of 10 bit converter
- ❑ white noise

sine wave: $A_{pp} = 2^{\text{NOB}} \text{ LSB}$

$$A_{\text{rms}} = \frac{\text{LSB} 2^{\text{NOB}}}{2\sqrt{2}}$$

noise power: $\sigma = \frac{\text{LSB}}{\sqrt{12}}$

signal-to-noise ratio:

$$\text{SNR} = \frac{A_{\text{rms}}}{\sigma} = \frac{\text{LSB} 2^{\text{NOB}}}{2\sqrt{2}} \frac{\sqrt{12}}{\text{LSB}}$$

$$\text{SNR} = \sqrt{1.5} 2^{\text{NOB}}$$

$$\text{SNR} = 6.02 \cdot \text{NOB} + 1.76 \text{ dB}$$

Dynamic Specifications of Nyquist A/D-Converters (I)

real spectrum

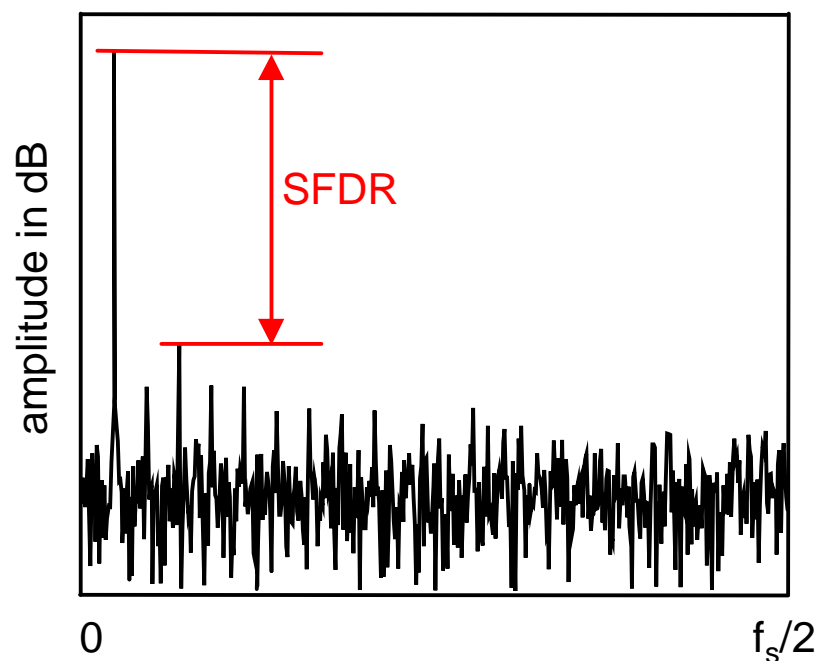

- ❑ SFDR:
spurious free dynamic range
- ❑ SNR:
signal-to-noise ratio
- ❑ SNDR:
signal-to-noise and distortion ratio
ideal quantizer: $\text{SNDR} = 6.02 \cdot \text{NOB} + 1.76$
- ❑ ENOB:
effective number of bits

$$\text{ENOB} = \frac{\text{SNDR} - 1.76}{6.02}$$

Dynamic Specifications of Nyquist A/D-Converters (II)

clock jitter

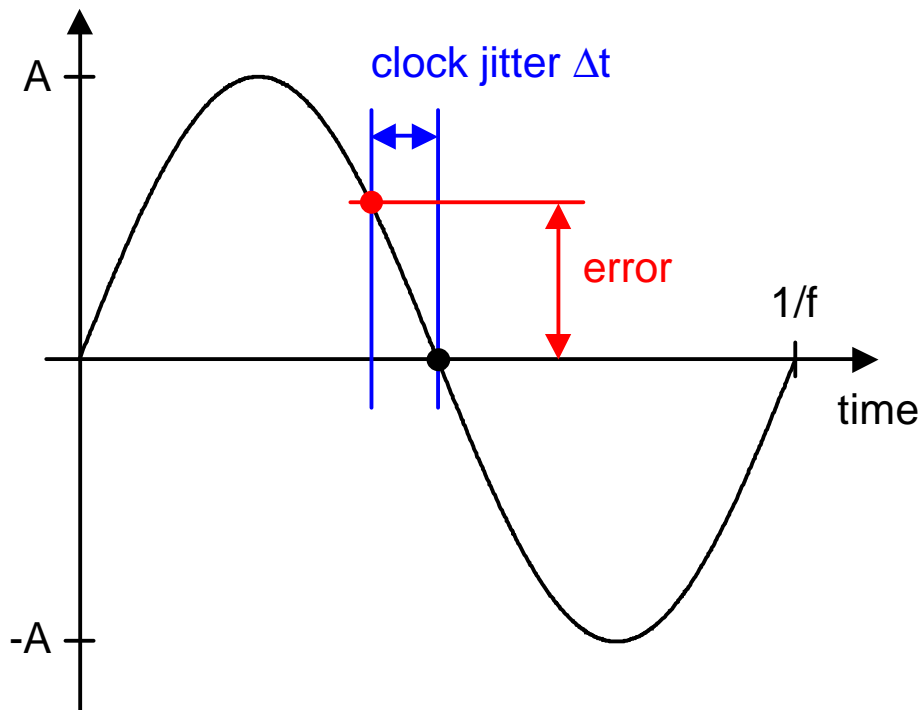

- maximum sampling uncertainty

$$u = A \sin(\omega t)$$

$$\left. \frac{du}{dt} \right|_{\max} = A\omega$$

$$\Delta u = A\omega\Delta t$$

$$1 \text{ LSB} = \frac{2A}{2^{\text{NOB}}}$$

$$\Delta u < 1 \text{ LSB} \Rightarrow$$

$$\Delta t < \frac{2^{-\text{NOB}}}{\pi \cdot f}$$

- examples:

$$\text{NOB} = 8 \text{ Bit} \quad f = 10 \text{ MHz} \quad \Delta t < 31 \text{ ps}$$

$$\text{NOB} = 12 \text{ Bit} \quad f = 100 \text{ MHz} \quad \Delta t < 0.77 \text{ ps}$$

Basic High-Speed A/D Converter

❑ flash converter

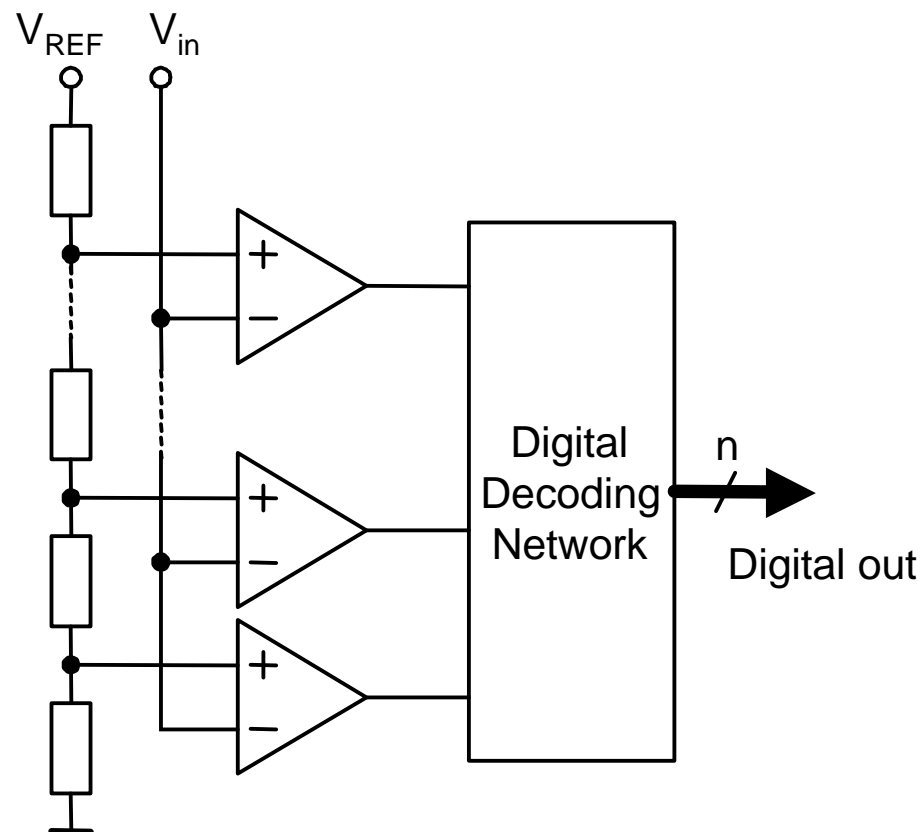

- ❑ fastest architecture
- ❑ power and area consumption increase **exponentially** with number of bits
- ❑ practical implementation **6 ... 8 bit**

Improved Architectures

□ goal: reduce number of comparators

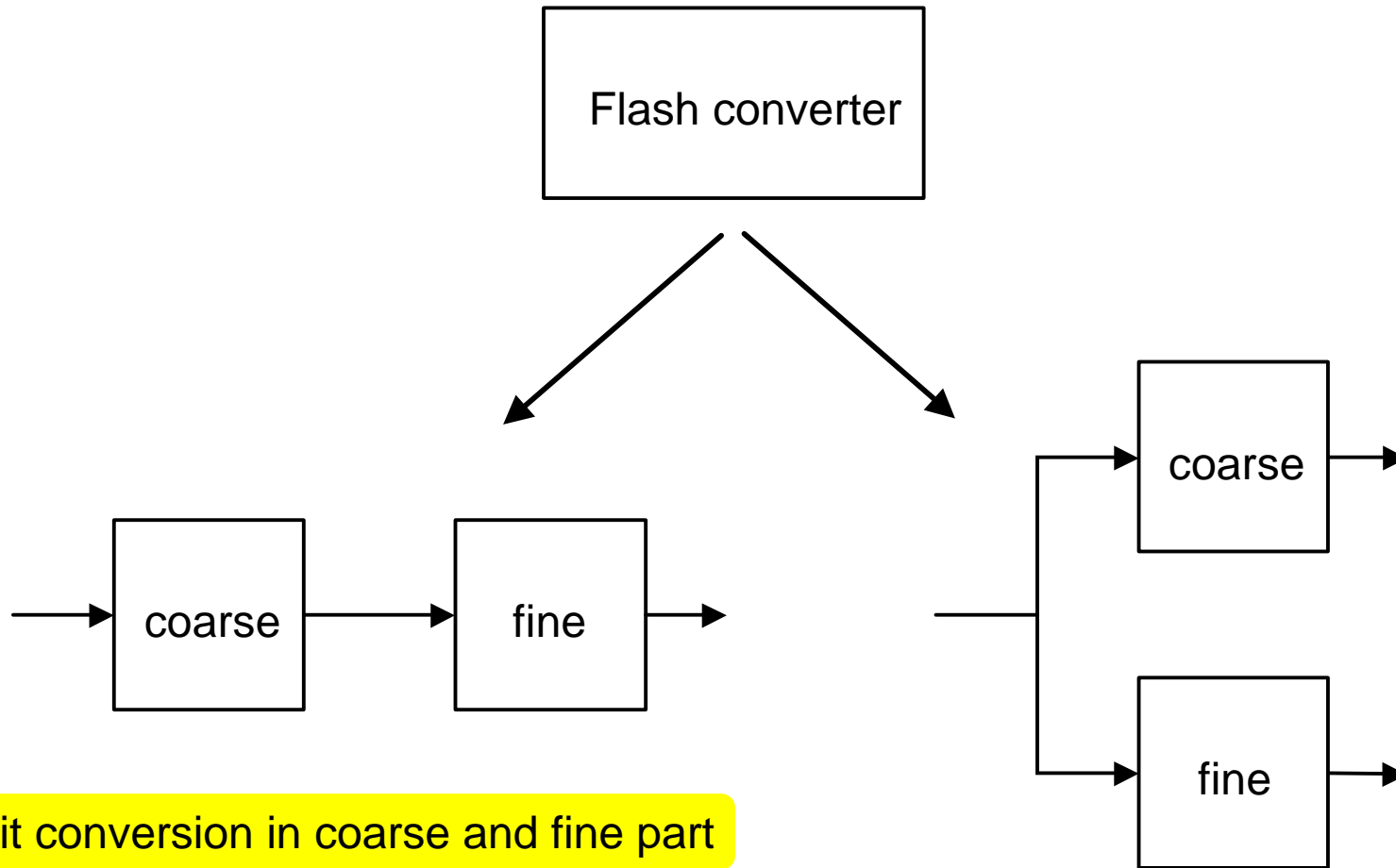

□ split conversion in coarse and fine part

Two-Step Flash A/D Converter

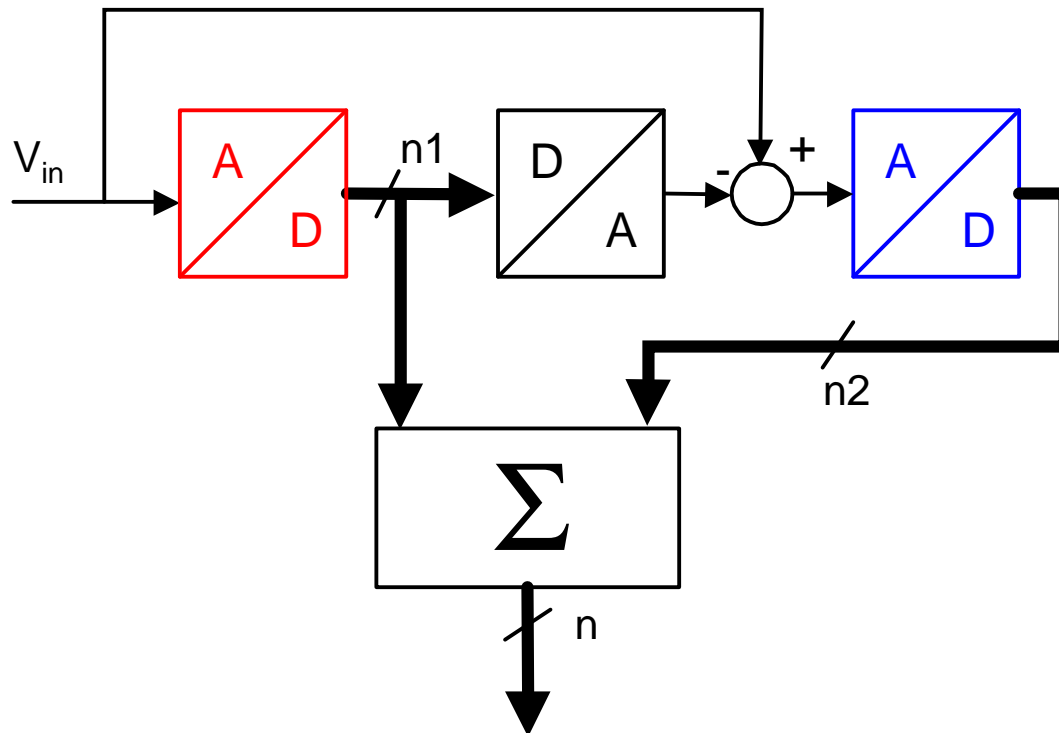

- ❑ coarse and fine conversion
- ❑ area substantially smaller than full flash ADC
- ❑ speed: slower than full flash ADC
- ❑ suitable for resolutions > 8 bit

Pipelined A/D Converter

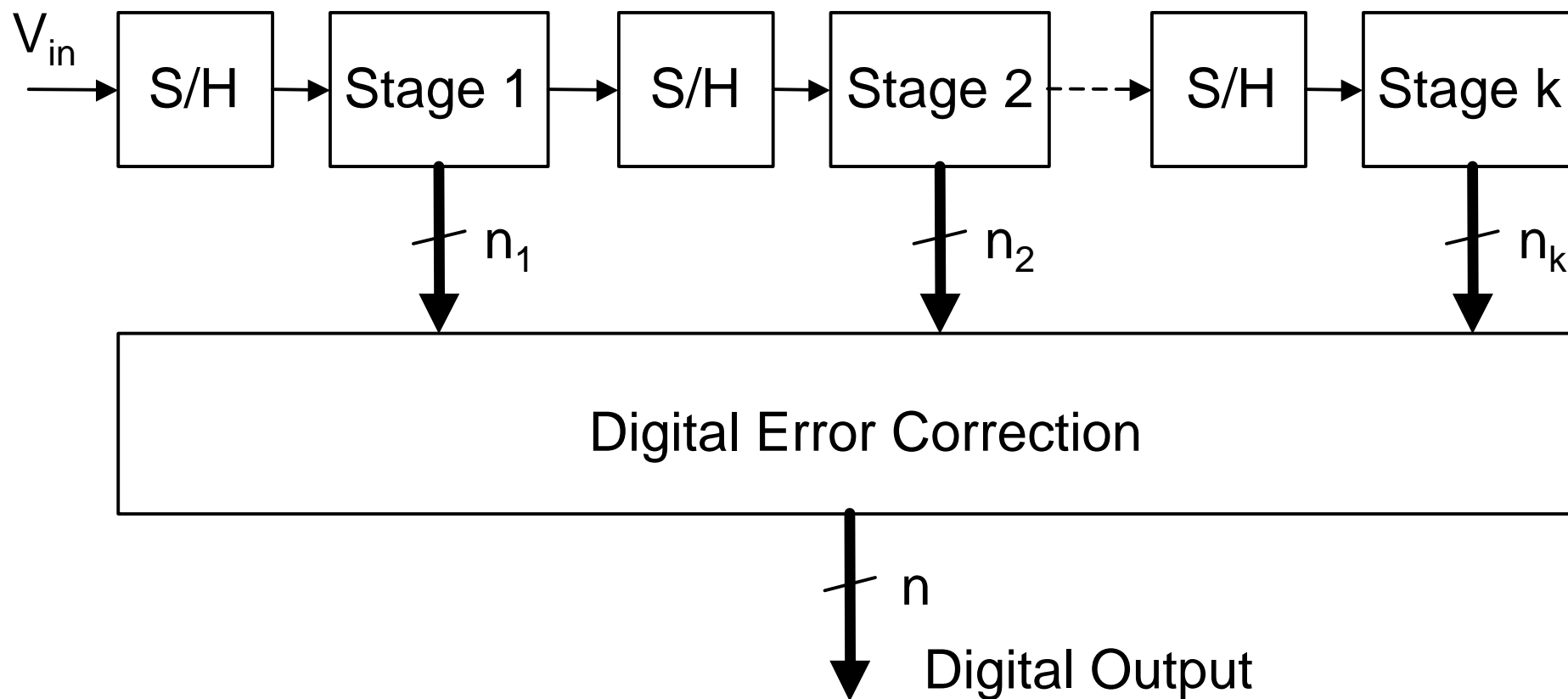

□ arbitrary number of stages

□ all stages operate independently

From Flash to Folding

principle

- ❑ coarse quantization still of flash-type
- ❑ analog preprocessing for fine quantization

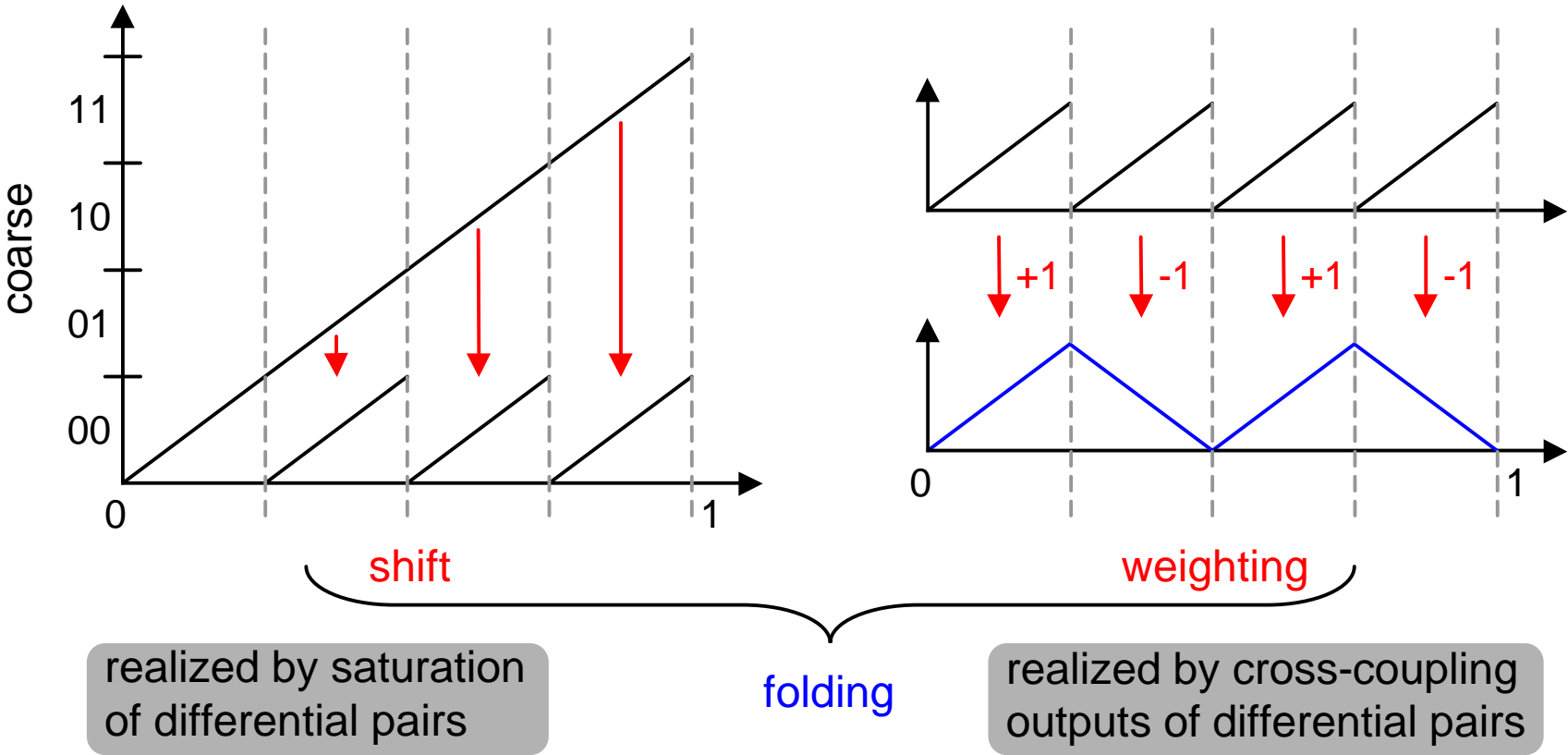

Basic Operation

partitioning of coarse and fine quantization

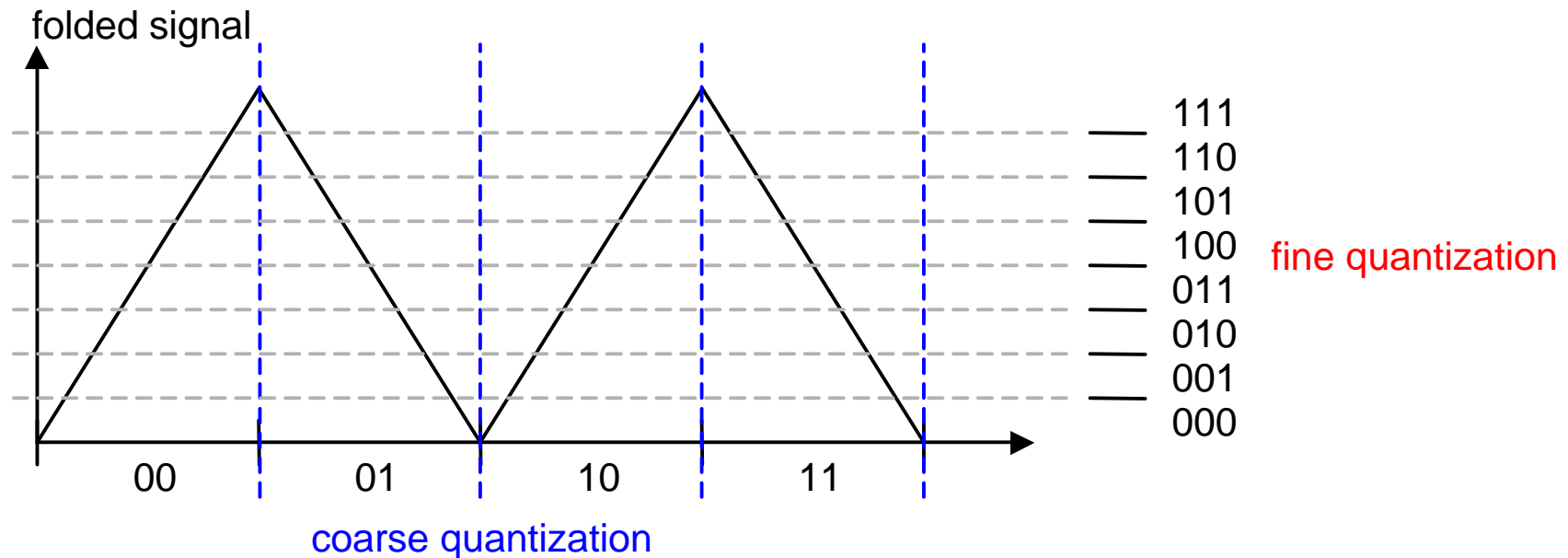

- concurrent coarse and fine quantization
- reduction in number of comparators corresponds to 2-step flash converter

Parallel Folded Signals

problems

- ❑ inaccurate quantization at the tops of folded signal
- ❑ sharp signal transitions hard to realize by practical circuits

solution

- ❑ use **two** folded signals shifted by 90° ($1/2$ LSB of coarse quantizer)
⇒ for any input level one signal is near its zero-crossing
- ❑ in general use A parallel signals shifted by $180^\circ/A$ or $1/A$ LSB

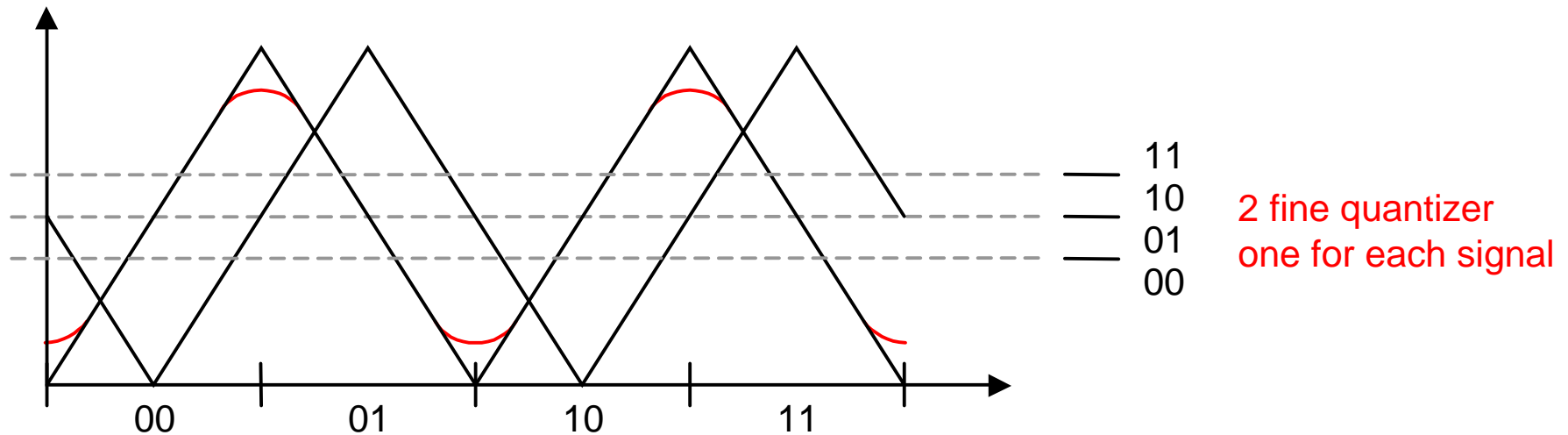

realized by selection of reference voltages of differential pairs

Interpolation

problem

❑ linearity in folded signal still necessary

solution

❑ create additional folded signals by linear interpolation

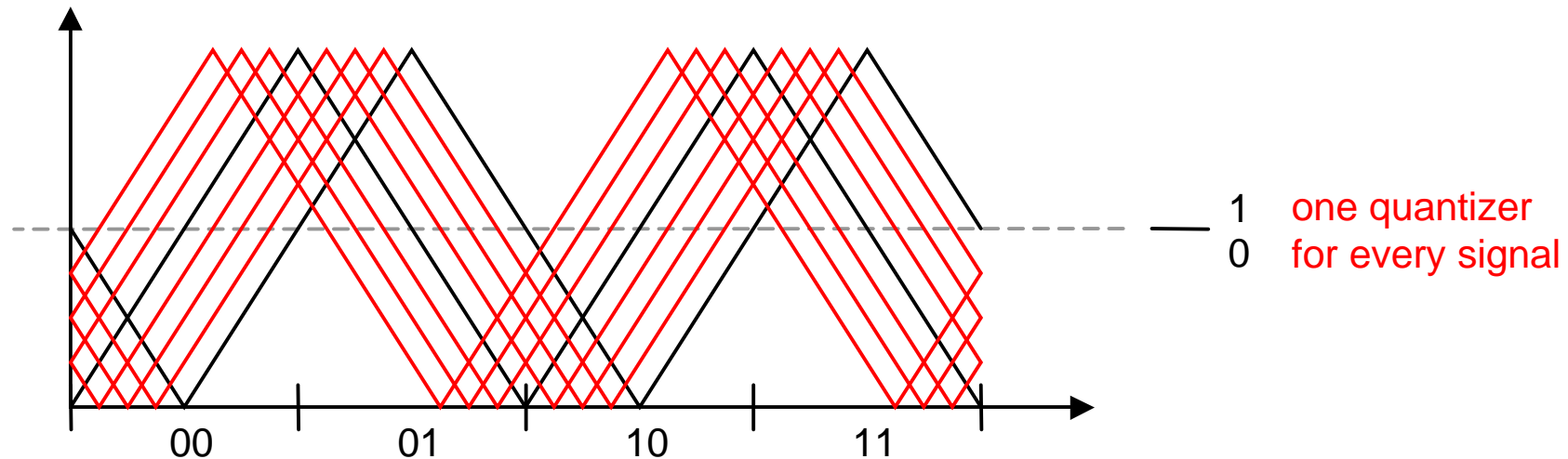

❑ only one quantizer for every folded signal

❑ only zero-crossings contain information

realized by insertion of resistors between adjacent folded signals

Block Diagram

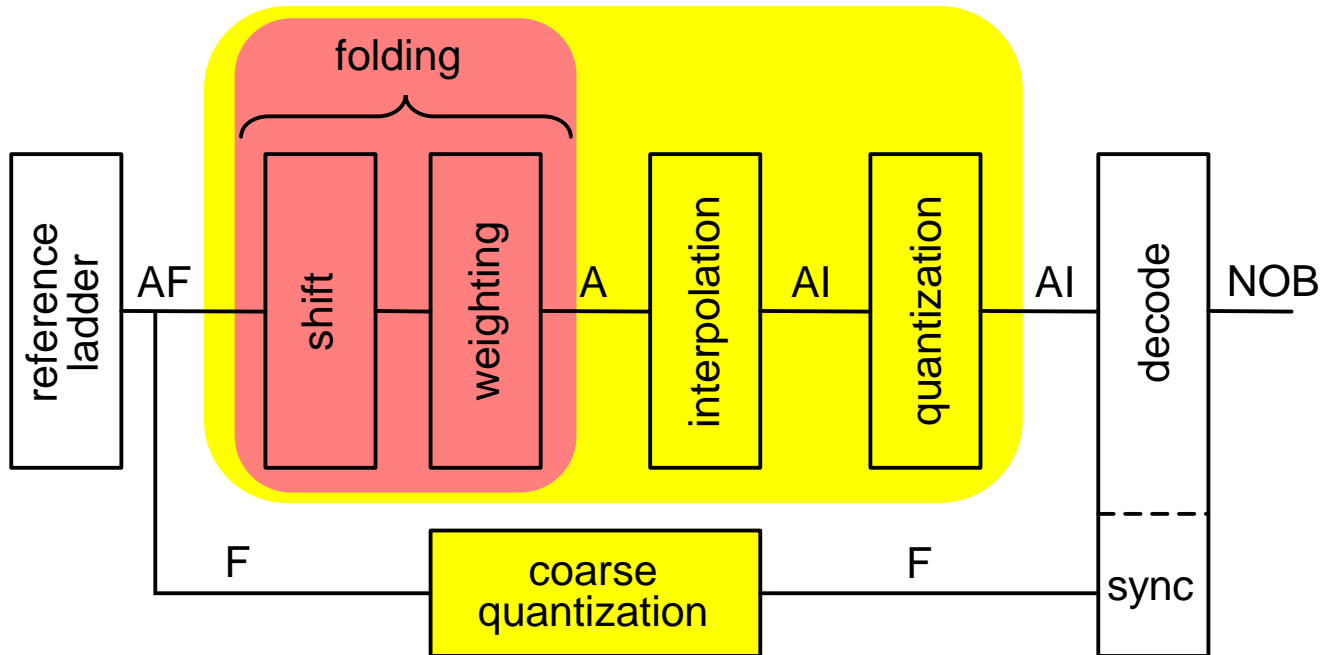

□ Definitions

- F folding factor
- A parallel folding stages
- I interpolation factor
- NOB number of Bits

- different propagation times through coarse and fine quantization stages
⇒ synchronization necessary
- can be implemented by simple digital logic

Summary

- ❑ Applications of Nyquist ADCs
- ❑ Static Specifications of Nyquist ADCs
 - offset and gain error
 - nonlinearity (INL, DNL)
 - quantization error
- ❑ Dynamic Specifications of Nyquist ADCs
 - spectrum related (SNR, SNDR, ENOB, SFDR)
 - clock jitter
- ❑ Basic High-Speed ADC
- ❑ From Flash ADC to Pipelined Converter
 - two step ADC
 - two step ADC with Sample-and-Hold
 - multistep ADC with Sample-and-Hold (Pipelined ADC)
- ❑ From Flash ADC to Folding and Interpolation Converter
 - what is folding (shift and weighting)
 - using parallel folded signals
 - interpolation